

# Bridgelux V6 Array Series



Product Data Sheet DS40  
BXRE-xxx0400-A, BXRE-xxx0400-B

## Introduction

The V Series LED Array products deliver high quality light in a compact and cost-effective solid-state lighting package. These Chip-on-Board (CoB) arrays can be efficiently driven at twice the nominal drive current, enabling design flexibility not previously possible. This high flux density light source is designed to support a wide range of high quality, low cost directional luminaires and replacement lamps for commercial and residential applications.

The V6 LED Array is available in a variety of electrical, CCT and CRI combinations providing substantial design flexibility and energy efficiencies.

Lighting system designs incorporating these LED Arrays deliver comparable performance to 7-13 Watt compact fluorescent and 25-50 Watt incandescent and halogen based luminaires, delivering increased system level efficacy and longer service life. Typical applications include, but are not limited to, replacement lamps, task, accent, spot, track, down light, wide area, security, and wall pack.

## Features

- Compact high flux density light source
- Uniform high quality illumination
- Minimum 70, 80 and 90 CRI options
- Streamlined thermal path
- Energy Star / ANSI compliant color binning structure with 3SDCM and 4SDCM options
- More energy efficient than incandescent, halogen and fluorescent lamps
- Low voltage DC operation
- Instant light with unlimited dimming

## Benefits

- Enhanced optical control
- Clean white light without pixilation
- High quality true color reproduction
- Significantly reduced thermal resistance and increased operating temperatures
- Uniform consistent white light
- Lower operating costs
- Easy to use with daylight and motion detectors to enable increased energy savings
- Reduced maintenance costs
- Environmentally friendly, no disposal issue

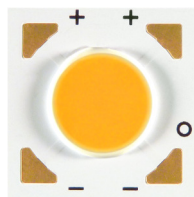

<b>Table of Contents</b>	<b>Page</b>
Typical Product Features	3
Product Nomenclature	3
Lumen Maintenance Characteristics	4
Environmental Compliance	4
UL Recognition	4
CE Recognition	4
Minor Product Change Policy	4
Case Temperature Measurement Point	4
Cautionary Statements	5
Selection Guide	6
Performance at Commonly Used Drive Currents	7
Electrical Characteristics	8
Absolute Maximum Ratings	9
Current vs. Forward Voltage Characteristics	10
Typical Luminous Flux vs. Current	11
Typical Chromaticity Characteristics vs. Temperature	12
Typical Radiation Pattern	14
Typical Color Spectrum	15
Mechanical Dimensions	16
Color Binning Information	17
Packaging and Labeling	20
Design Resources	22
About Bridgelux	23

## Typical Product Features

Bridgelux arrays are fully engineered devices that provide consistent thermal and optical performance on an engineered mechanical platform. The V Series arrays are the most compact chip-on-board devices across all of Bridgelux's LED Array products. The arrays incorporate several features to simplify design integration and assembly.

**Figure 1: Array Features**

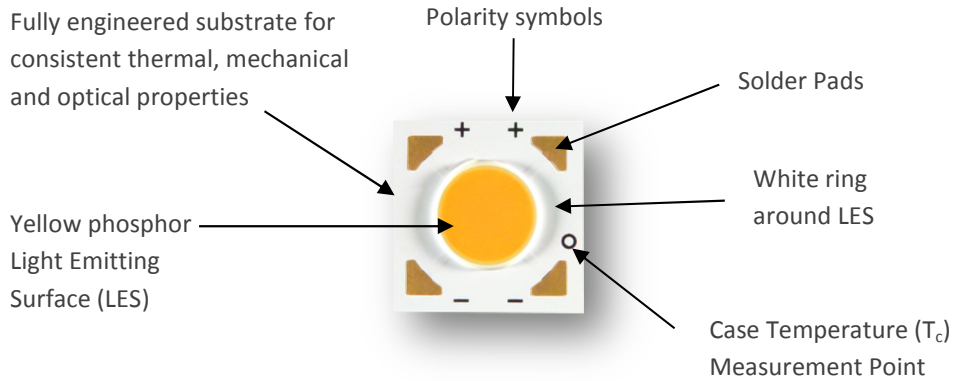

Note: Part number and lot codes are scribed on back of array encoded in a 2D barcode

## Product Nomenclature

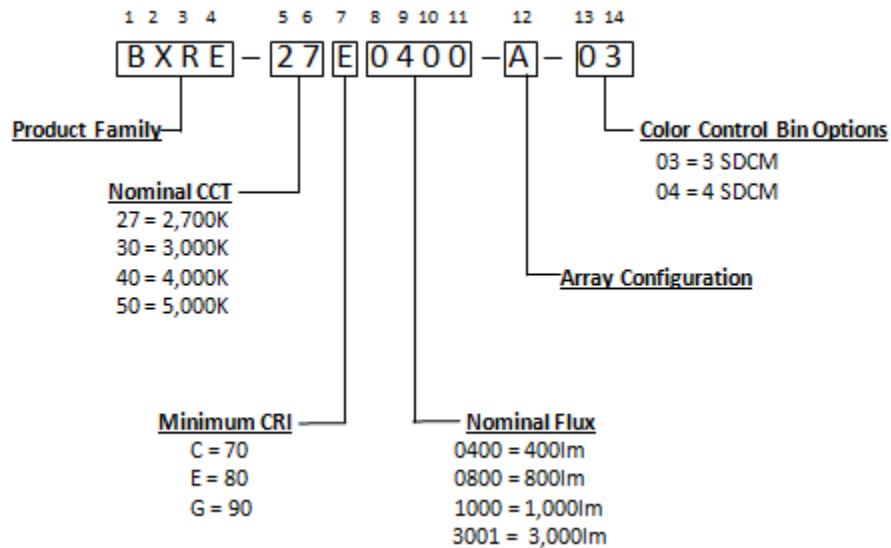

### **Lumen Maintenance Characteristics**

Bridgelux projects that its family of LED Array products will deliver, on average, greater than 70% lumen maintenance after 50,000 hours of operation at 2X the nominal drive current in Table 1. This performance assumes constant current operation at the nominal drive current with case temperature maintained at or below 85°C. For use beyond these typical operating conditions please consult your Bridgelux sales representative for further assistance.

These projections are based on a combination of package test data, semiconductor chip reliability data, a fundamental understanding of package related degradation mechanisms, and performance observed from products installed in the field using Bridgelux die technology. Bridgelux conducts lumen maintenance tests per LM80. Observation of design limits is required in order to achieve this projected lumen maintenance.

### **Environmental Compliance**

Bridgelux is committed to providing environmentally friendly products to the solid state lighting market. Bridgelux LED Arrays comply with the European Union directives on the restriction of hazardous substances in electronic equipment, namely the RoHS directive. Bridgelux does not intentionally add the following restricted materials to LED Array products: lead, mercury, cadmium, hexavalent chromium, polybrominated biphenyls (PBB) or polybrominated diphenyl ethers (PBDE).

### **UL Recognition**

Bridgelux secures UL recognition for all the LED Array products. Please refer to the UL file E350613 for the latest list of UL recognized Arrays. Bridgelux uses UL recognized materials with suitable flammability ratings in the LED Array to streamline the process for customers to secure UL listing of the final luminaire product.

### **CE Recognition**

In accordance with the relevant European Union directives, the family of LED Array products conform to the applicable requirements of the IEC/EN 62031:2008 (LED Modules for General Lighting Safety Specifications) and IEC 62471:2006 (Photobiological Safety of Lamps and Lamp Systems). Bridgelux maintains a CE Declaration of Conformity statement on its website and displays the CE mark on product packing labels.

### **Minor Product Change Policy**

The rigorous qualification testing on products offered by Bridgelux provides performance assurance. Slight cosmetic changes that do not affect form, fit, or function may occur as Bridgelux continues product optimization.

### **Case Temperature Measurement Point**

A case temperature ( $T_c$ ) measurement point location is included on the top surface of the Bridgelux LED Arrays as shown in Figure 12. The location of this measurement point is indicated in the mechanical dimensions section of this data sheet.

The purpose of this measurement point is to allow the user access to a measurement point closely linked to the true case temperature on the back surface of the LED Array. Once the LED Array is installed, it is challenging to measure the back surface of the array, or true case temperature.

Bridgelux has provided the case temperature measurement location in a manner which closely ties it to the true case temperature of the LED Array under steady state operation. Deviations between thermal measurements taken at the point indicated and the back of the LED Array differ by less than 1°C, providing a robust method to testing thermal operation once the product is installed.

## Cautionary Statements

### **CAUTION: CONTACT WITH LIGHT EMITTING SURFACE (LES)**

Avoid any contact with the Light Emitting Surface (LES) shown in Figure 12. Do not touch the Light Emitting Surface (LES) of the LED Array or apply mechanical stress to the yellow phosphor resin area – it could damage the LED Array.

Optics and reflectors must not be mounted in contact with the yellow phosphor resin area (LES) or the white ring that surrounds the yellow phosphor area. Using the white ring to secure optics can result in damage to the LED Array as the ring is not designed to act as a mechanical locating feature. Optical devices may be mounted on the top surface of the LED Array substrate outside of the white ring maximum OD as specified in the product data sheet. Use the mechanical features of the LED Array substrate edges and/or mounting holes to locate and secure the optical device as needed.

### **CAUTION: EYE SAFETY**

Eye safety classification for the use of Bridgelux LED Arrays is in accordance with IEC specification 62471; Photobiological Safety of Lamps and Lamp Systems. Bridgelux LED Arrays are classified as Risk Group 1 (Low Risk) when operated at or below their maximum drive current. Please use appropriate precautions. It is important that employees working with LEDs are trained to use them safely.

### **CAUTION: RISK OF BURN**

Do not touch the LED Array during operation. Allow the LED Array to cool for a sufficient period of time before handling. The LED Array may reach elevated temperatures such that it can burn skin when touched.

### **CAUTION: CHEMICAL EXPOSURE HAZARD**

Exposure to some chemicals commonly used in luminaire manufacturing and assembly can cause damage to the LED Array. Please consult Application Note AN41 for additional information.

## Selection Guide

The following configurations are available:

**Table 1: Selection Guide, Pulsed Measurement Data ( $T_j = T_c = 25^\circ\text{C}$ )**

Part Number	Nominal CCT <sup>[1]</sup> (K)	CRI <sup>[2]</sup>	Nominal Drive Current <sup>[3]</sup> (mA)	Typical Pulsed Flux <sup>[4][5][6]</sup> $T_c = 25^\circ\text{C}$ (lm)	Minimum Pulsed Flux <sup>[6][7]</sup> $T_c = 25^\circ\text{C}$ (lm)	Typical $V_f$ (V)	Typical Power (W)	Typical Efficacy (lm/W)
BXRE-27E0400-A-xx	2700	80	175	340	305	17.8	3.1	109
BXRE-27E0400-B-xx	2700	80	350	340	305	8.9	3.1	109
BXRE-27G0400-A-xx	2700	90	175	280	250	17.8	3.1	90
BXRE-27G0400-B-xx	2700	90	350	280	250	8.9	3.1	90
BXRE-30E0400-A-xx	3000	80	175	361	325	17.8	3.1	116
BXRE-30E0400-B-xx	3000	80	350	361	325	8.9	3.1	116
BXRE-30G0400-A-xx	3000	90	175	310	280	17.8	3.1	100
BXRE-30G0400-B-xx	3000	90	350	310	280	8.9	3.1	100
BXRE-40E0400-A-xx	4000	80	175	380	340	17.8	3.1	122
BXRE-40E0400-B-xx	4000	80	350	380	340	8.9	3.1	122
BXRE-50C0400-A-xx	5000	70	175	430	385	17.8	3.1	138
BXRE-50C0400-B-xx	5000	70	350	430	385	8.9	3.1	138
BXRE-50E0400-A-xx	5000	80	175	392	350	17.8	3.1	126
BXRE-50E0400-B-xx	5000	80	350	392	350	8.9	3.1	126

**Table 2: Selection Guide, Stabilized DC Performance ( $T_c = 85^\circ\text{C}$ )<sup>[8][9]</sup>**

Part Number	Nominal CCT <sup>[1]</sup> (K)	CRI <sup>[2]</sup>	Nominal Drive Current <sup>[3]</sup> (mA)	Typical DC Flux $T_c = 85^\circ\text{C}$ (lm)	Minimum DC Flux <sup>[10]</sup> $T_c = 85^\circ\text{C}$ (lm)	Typical $V_f$ (V)	Typical Power (W)	Typical Efficacy (lm/W)
BXRE-27E0400-A-xx	2700	80	175	306	275	17.4	3.0	101
BXRE-27E0400-B-xx	2700	80	350	306	275	8.7	3.0	101
BXRE-27G0400-A-xx	2700	90	175	252	225	17.4	3.0	83
BXRE-27G0400-B-xx	2700	90	350	252	225	8.7	3.0	83
BXRE-30E0400-A-xx	3000	80	175	325	293	17.4	3.0	107
BXRE-30E0400-B-xx	3000	80	350	325	293	8.7	3.0	107
BXRE-30G0400-A-xx	3000	90	175	280	252	17.4	3.0	92
BXRE-30G0400-B-xx	3000	90	350	280	252	8.7	3.0	92
BXRE-40E0400-A-xx	4000	80	175	342	306	17.4	3.0	112
BXRE-40E0400-B-xx	4000	80	350	342	306	8.7	3.0	113
BXRE-50C0400-A-xx	5000	70	175	387	347	17.4	3.0	127
BXRE-50C0400-B-xx	5000	70	350	387	347	8.7	3.0	128
BXRE-50E0400-A-xx	5000	80	175	353	315	17.4	3.0	116
BXRE-50E0400-B-xx	5000	80	350	353	315	8.7	3.0	116

Notes for Tables 1 & 2:

- Nominal CCT as defined by ANSI C78.377-2011.
- CRI Values are minimums. Minimum R9 value for 80 CRI products is 0, the minimum R9 values for 90 CRI products is 50.
- Drive current is referred to as nominal drive current.
- Products tested under pulsed condition (10ms pulse width) at rated test current where  $T_j$  (junction temperature) =  $T_c$  (case temperature) =  $25^\circ\text{C}$ .
- Typical performance values are provided as a reference only and are not a guarantee of performance.
- Bridgelux maintains a  $\pm 7\%$  tolerance on flux measurements.
- Minimum flux values at the rated test current are guaranteed by 100% test.
- Typical stabilized DC performance values are provided as reference only and are not a guarantee of performance.
- Typical performance is estimated based on operation under DC (direct current) with LED array mounted onto a heat sink with thermal interface material and the case temperature maintained at  $85^\circ\text{C}$ . Based on Bridgelux test setup, values may vary depending on the thermal design of the luminaire and/or the exposed environment to which the product is subjected.
- Minimum flux values at elevated temperatures are provided for reference only and are not guaranteed by 100% production testing. Based on Bridgelux test setup, values may vary depending on the thermal design of the luminaire and/or the exposed environment to which the product is subjected.

## Performance at Commonly Used Drive Currents

**Table 3: Product Performance at Commonly Used Drive Currents**

Part Number	CRI	Drive Current (mA) <sup>[1]</sup>	Typical V <sub>f</sub> T <sub>c</sub> = 25°C (V)	Typical Power T <sub>c</sub> = 25°C (W)	Typical Flux T <sub>c</sub> = 25°C (lm) <sup>[2]</sup>	Typical DC Flux T <sub>c</sub> = 85°C <sup>[2][3]</sup> (lm)	Typical Efficacy T <sub>c</sub> = 25°C (lm/W)
BXRE-27E0400-A-03	80	175	<b>17.8</b>	<b>3.1</b>	<b>340</b>	<b>306</b>	<b>109</b>
		250	18.4	4.6	464	417	101
		350	19.2	6.7	613	551	91
BXRE-27E0400-B-03	80	175	8.5	<b>1.5</b>	181	163	<b>122</b>
		<b>350</b>	<b>8.9</b>	<b>3.1</b>	<b>340</b>	<b>306</b>	<b>109</b>
		500	9.2	4.6	462	416	101
BXRE-27G0400-A-03	90	175	<b>17.8</b>	<b>3.1</b>	<b>280</b>	<b>252</b>	<b>90</b>
		250	18.4	4.6	382	344	83
		350	19.2	6.7	505	454	75
BXRE-27G0400-B-03	90	175	8.5	<b>1.5</b>	149	134	<b>100</b>
		<b>350</b>	<b>8.9</b>	<b>3.1</b>	<b>280</b>	<b>252</b>	<b>90</b>
		500	9.2	4.6	381	343	83
BXRE-30E0400-A-03	80	175	<b>17.8</b>	<b>3.1</b>	<b>361</b>	<b>325</b>	<b>116</b>
		250	18.4	4.6	492	443	107
		350	19.2	6.7	650	585	97
BXRE-30E0400-B-03	80	175	8.5	<b>1.5</b>	192	173	<b>129</b>
		<b>350</b>	<b>8.9</b>	<b>3.1</b>	<b>361</b>	<b>325</b>	<b>116</b>
		500	9.2	4.6	491	442	107
BXRE-30G0400-A-03	90	175	<b>17.8</b>	<b>3.1</b>	<b>310</b>	<b>280</b>	<b>100</b>
		250	18.4	4.6	423	380	92
		350	19.2	6.7	559	503	83
BXRE-30G0400-B-03	90	175	8.5	<b>1.5</b>	165	149	<b>111</b>
		<b>350</b>	<b>8.9</b>	<b>3.1</b>	<b>310</b>	<b>280</b>	<b>100</b>
		500	9.2	4.6	422	379	92
BXRE-40E0400-A-03	80	175	<b>17.8</b>	<b>3.1</b>	<b>380</b>	<b>342</b>	<b>122</b>
		250	18.4	4.6	518	466	113
		350	19.2	6.7	685	616	102
BXRE-40E0400-B-03	80	175	8.5	<b>1.5</b>	202	182	<b>136</b>
		<b>350</b>	<b>8.9</b>	<b>3.1</b>	<b>380</b>	<b>342</b>	<b>122</b>
		500	9.2	4.6	517	465	112
BXRE-50C0400-A-04	70	175	<b>17.8</b>	<b>3.1</b>	<b>430</b>	<b>387</b>	<b>138</b>
		250	18.4	4.6	586	528	127
		350	19.2	6.7	775	697	115
BXRE-50C0400-B-04	70	175	8.5	<b>1.5</b>	229	206	<b>154</b>
		<b>350</b>	<b>8.9</b>	<b>3.1</b>	<b>430</b>	<b>387</b>	<b>138</b>
		500	9.2	4.6	585	526	127
BXRE-50E0400-A-04	80	175	<b>17.8</b>	<b>3.1</b>	<b>392</b>	<b>353</b>	<b>126</b>
		250	18.4	4.6	535	481	116
		350	19.2	6.7	706	636	105
BXRE-50E0400-B-04	80	175	8.5	<b>1.5</b>	209	188	<b>141</b>
		<b>350</b>	<b>8.9</b>	<b>3.1</b>	<b>392</b>	<b>353</b>	<b>126</b>
		500	9.2	4.6	533	480	116
		700	9.6	6.7	705	634	105

Notes for Table 3:

1. Values in bold correspond to performance at nominal drive current listed in Table 1. Alternate drive currents in Table 3 are provided for reference only and are not a guarantee of performance.
2. Bridgelux maintains a ± 7% tolerance on flux measurements.
3. Typical stabilized DC performance values are provided as reference only and are not a guarantee of performance.

## Electrical Characteristics

Table 4: Electrical Characteristics

Part Number	Drive Current (mA)	Forward Voltage Pulsed, $T_c = 25^\circ\text{C}$ (V) <sup>[1][2]</sup>			Typical Coefficient of Forward Voltage $\Delta V_f / \Delta T_c$ <sup>[3]</sup> (mV/ $^\circ\text{C}$ )	Typical Thermal Resistance Junction to Case $R\theta_{j-c}$ <sup>[4]</sup> (C/W)	Driver Selection Voltages (V) <sup>[5]</sup>	
		Minimum	Typical	Maximum			$V_f$ Min. Hot $T_c = 105^\circ\text{C}$ (V)	$V_f$ Max. Cold $T_c = -40^\circ\text{C}$ (V)
BXRE-xxx0400-A-xx	175	16.5	<b>17.8</b>	19.1	-7	1.25	15.9	19.6
	350	17.6	19.2	20.6	-7	1.72	17.0	21.1
BXRE-xxx0400-B-xx	350	8.2	<b>8.9</b>	9.6	-4	1.25	7.9	9.9
	700	8.8	9.7	10.4	-4	1.72	8.5	10.7

Notes for Table 4:

1. Parts are tested in pulsed conditions at the nominal drive current (indicated in bold font),  $T_c = 25^\circ\text{C}$ . Pulse width is 10 ms.
2. Voltage minimum and maximum are provided as a reference only and are not a guarantee of performance.
3. Typical Coefficient of Forward Voltage tolerance is  $\pm 0.1$  for nominal current.
4. Thermal resistance values are based from test data of 3000K 80CRI product.
5. Forward Voltage ( $V_f$ ) min hot and ( $V_f$ ) max cold values are provided as reference only and are not guaranteed by test. These values are provided to aid in driver design and selection over the operating range of the product.



## Absolute Maximum Ratings

**Table 5: Maximum Ratings**

Parameter	Maximum Rating	
LED Junction Temperature ( $T_j$ )	150°C	
Storage Temperature	-40°C to +105°C	
Operating Case Temperature <sup>[1]</sup> ( $T_c$ )	105°C	
Soldering Temperature <sup>[2]</sup>	350°C or lower for a maximum of 3.5 seconds	
	<b>BXRE-xxx0400-A-xx</b>	<b>BXRE-xxx0400-B-xx</b>
Maximum Drive Current <sup>[3][4][5]</sup>	350 mA	700 mA
Maximum Peak Pulsed Drive Current <sup>[6][7]</sup>	500 mA	1000mA
Maximum Reverse Voltage <sup>[8]</sup>	-30 V	-15 V

Notes for Table 5:

1. For IEC 62717 requirement, please consult your Bridgelux sales representative.
2. Refer to Bridgelux Application Note AN41: Assembly Considerations for Bridgelux LED Arrays.
3. DC Forward Current for LM-80 is the maximum drive current for which LM-80 data is currently available.
4. Lumen maintenance (L70) and lifetime predictions are valid for drive current and case temperature conditions used for LM-80 testing as included in the applicable LM-80 test report for these arrays.
5. Arrays may be driven at higher currents however lumen maintenance may be reduced.
6. Bridgelux recommends a maximum duty cycle of 10% when operating LED Arrays at the maximum peak pulsed current specified.
7. Maximum peak pulsed currents are values at which the LED Array can be driven without catastrophic failures.
8. Light emitting diodes are not designed to be driven in reverse voltage and will not produce light under this condition. Maximum rating provided for reference only.

## Current vs. Forward Voltage Characteristics

Figure 2: Typical Current vs. Voltage ( $T_j=T_c=25^\circ\text{C}$ ) – BXRE-xxx0400-A-xx

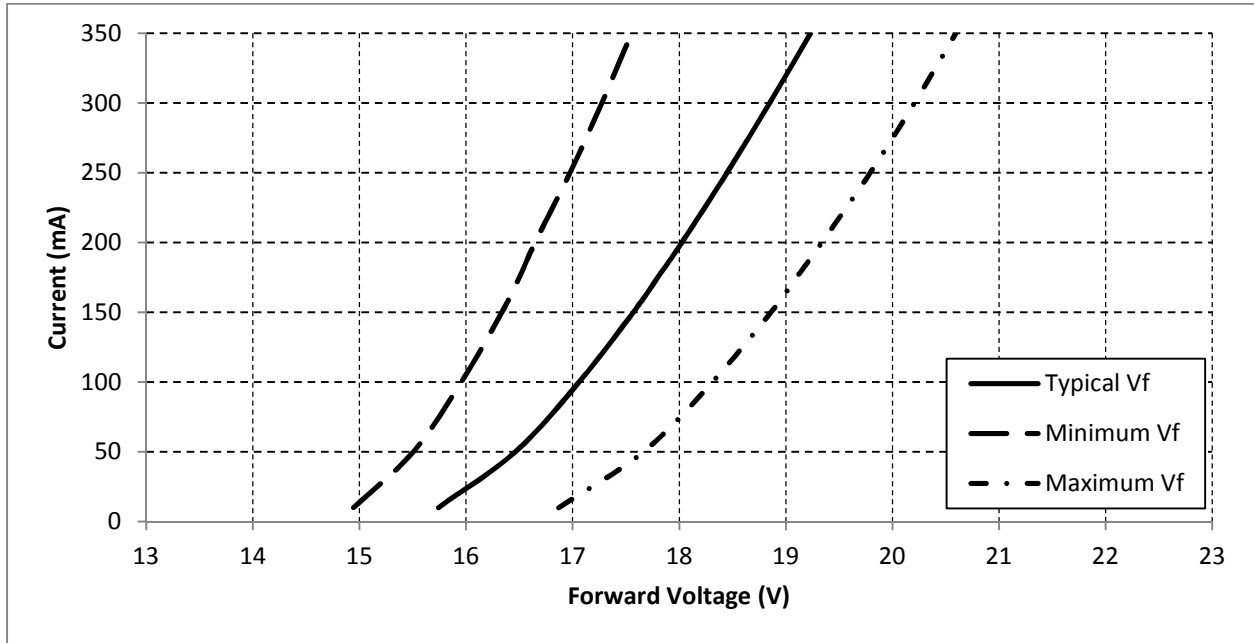
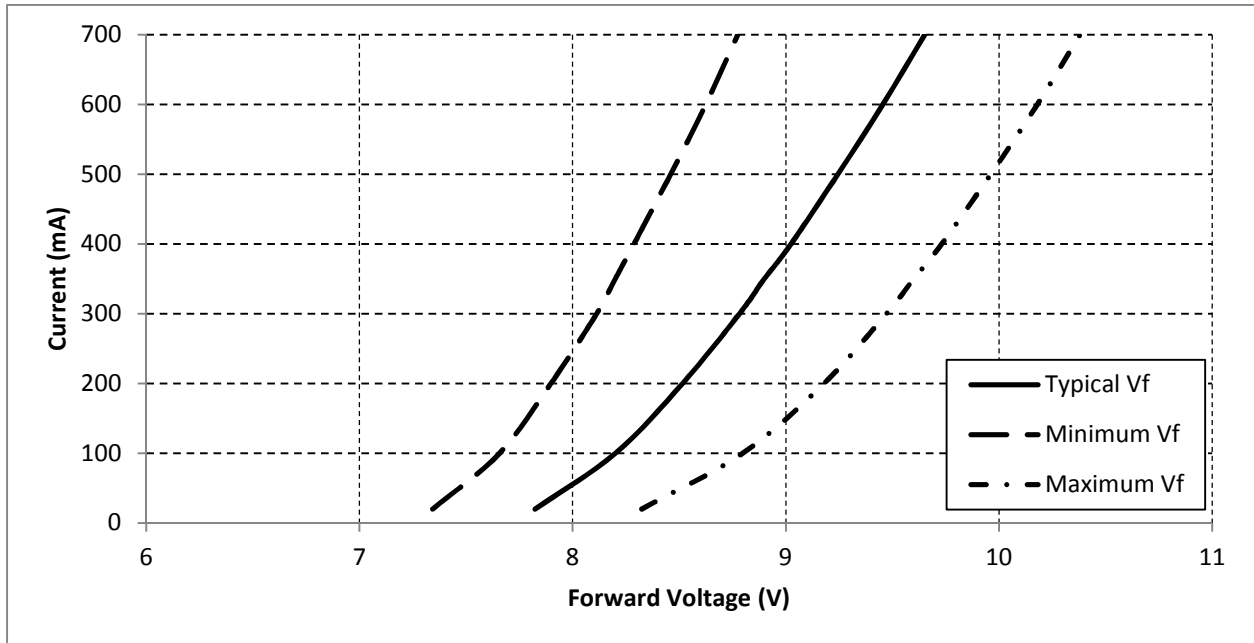

Figure 3: Typical Current vs. Voltage ( $T_j=T_c=25^\circ\text{C}$ ) – BXRE-xxx0400-B-xx



## Typical Luminous Flux vs. Current

Typical performance at any drive current can be derived from the current versus voltage characteristics shown in Figures 2 and 3 and the flux versus current characteristics shown in Figures 4 and 5. Normalized typical flux corresponds to LED tested under pulsed conditions where junction temperature ( $T_j$ ) = case temperature ( $T_c$ ) = 25°C.

**Figure 4: Typical Flux vs. Current – BXRE-xxx0400-A-xx**

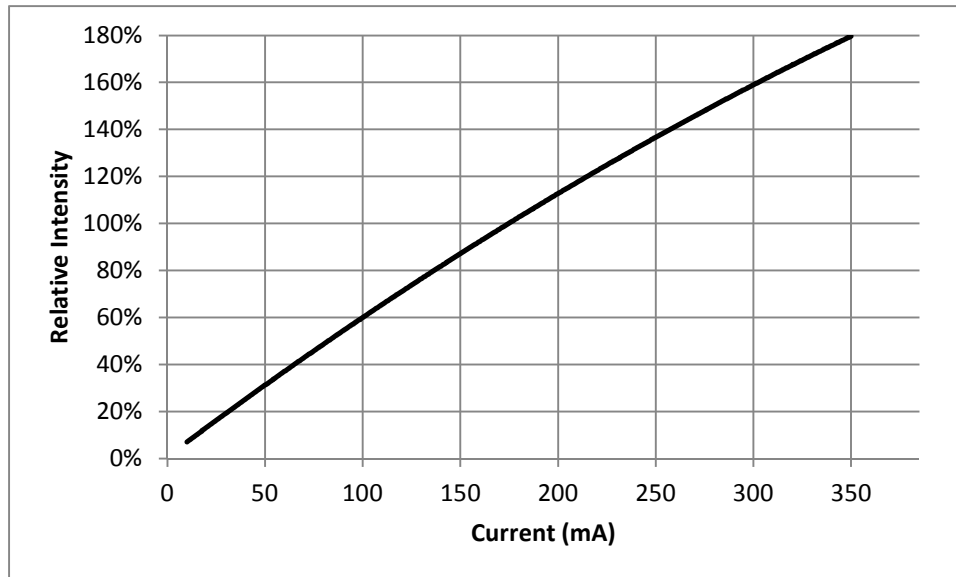

**Figure 5: Typical Flux vs. Current – BXRE-xxx0400-B-xx**

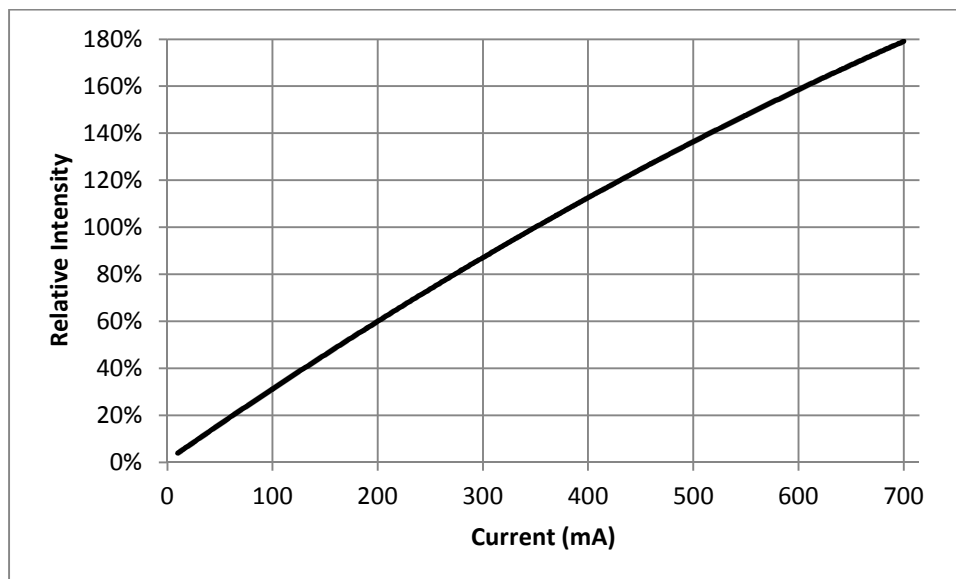

Note: Bridgelux does not recommend driving high power LED Arrays at low currents. Doing so may produce unpredictable results. Pulse width modulation (PWM) is recommended for dimming effects.

## Typical Chromaticity Characteristics vs. Temperature

Figure 6: Typical Flux vs. Case Temperature

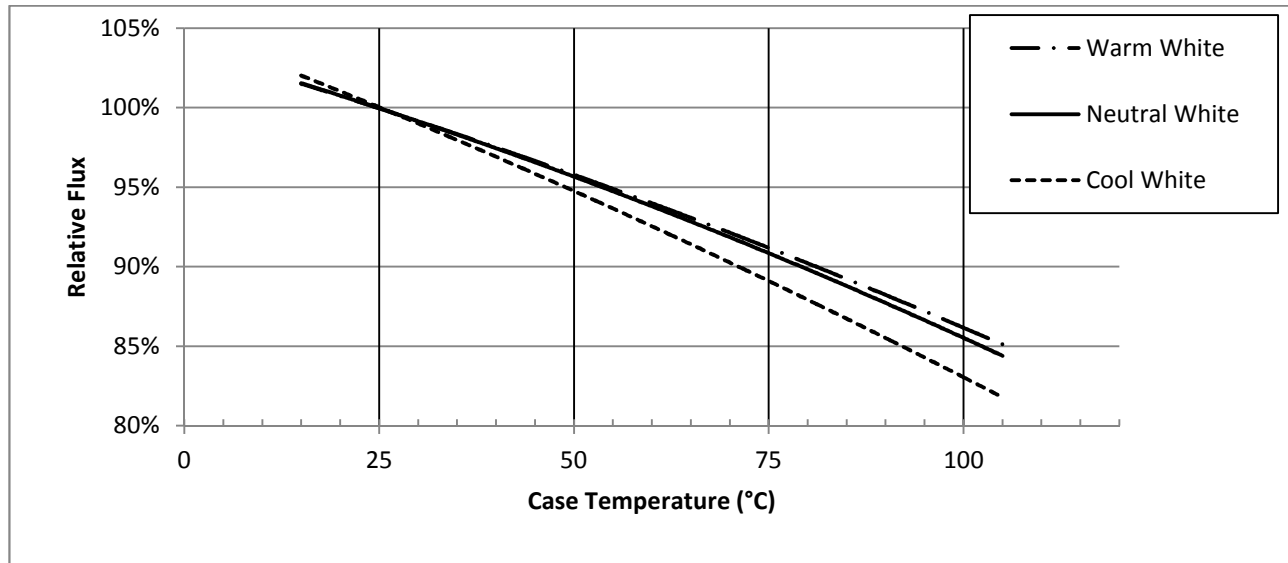

Note for Figures 6, 7 and 8:

1. Characteristics shown for Warm White based on 3000K and 80CRI.
2. Characteristics shown for Neutral White based on 4000K and 80CRI.
3. Characteristics shown for Cool White based on 5000K and 70CRI.

## Typical Chromaticity Characteristics vs. Temperature (continued)

Figure 7: Typical ccx Shift vs. Case Temperature

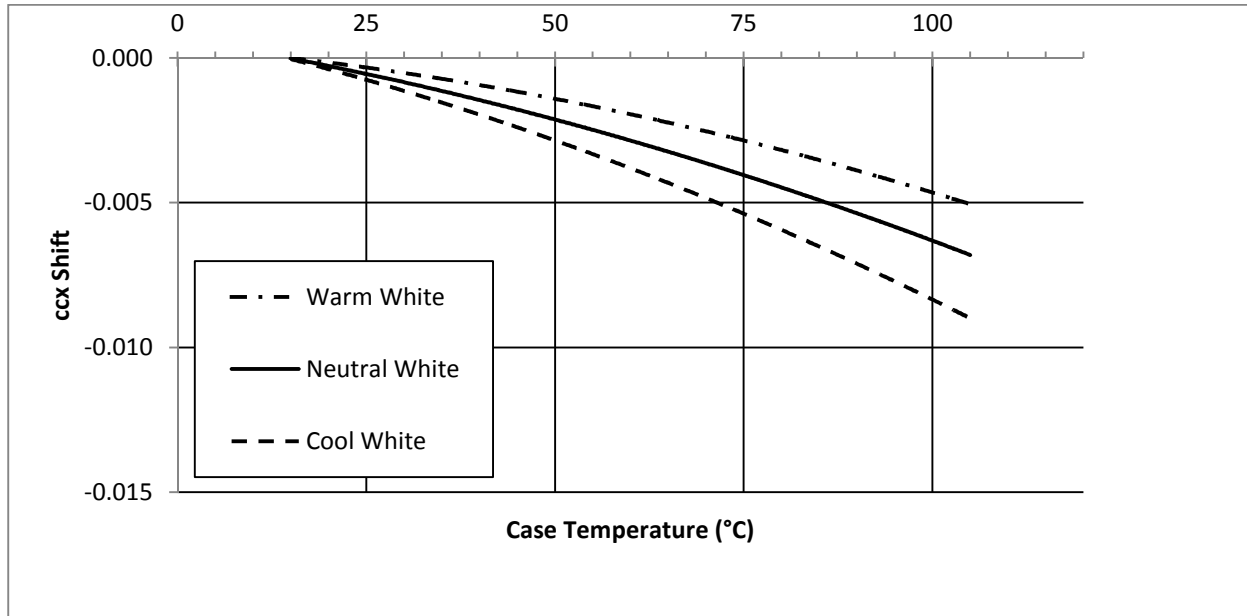
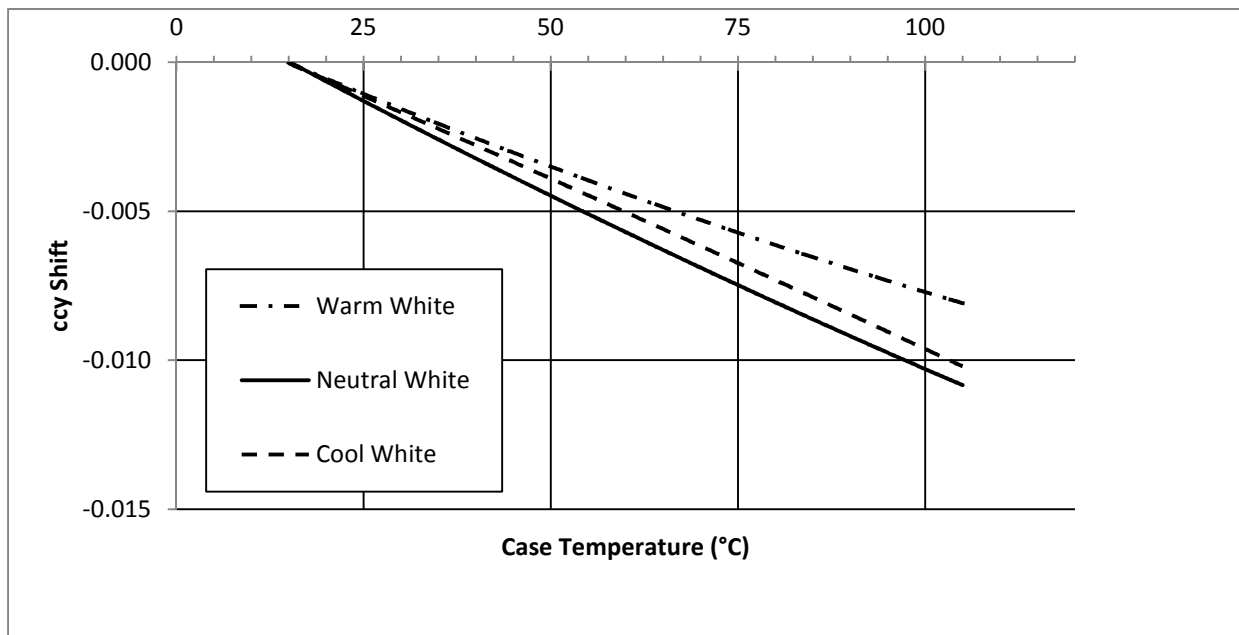

Figure 8: Typical ccy Shift vs. Case Temperature



Note for Figures 6, 7 and 8:

1. Characteristics shown for Warm White based on 3000K and 80CRI.
2. Characteristics shown for Neutral White based on 4000K and 80CRI.
3. Characteristics shown for Cool White based on 5000K and 70CRI.

# Typical Radiation Pattern

Figure 9: Typical Spatial Radiation Pattern

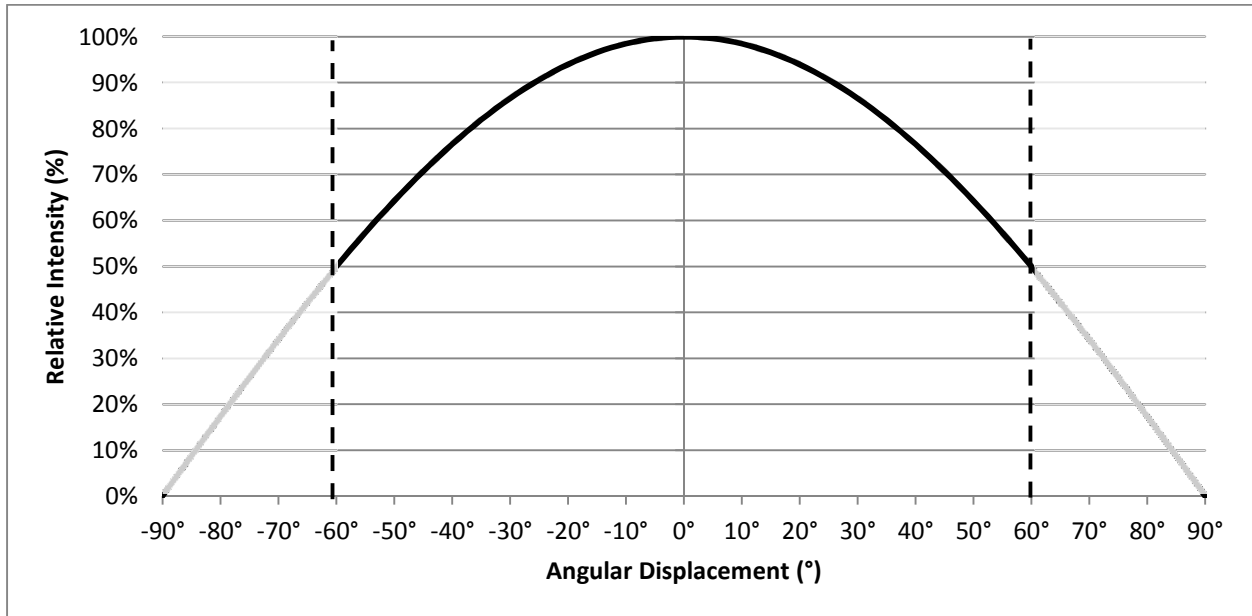

Notes for Figure 9:

1. Typical viewing angle is 120°.
2. The viewing angle is defined as the off axis angle from the centerline where  $I_v$  is  $\frac{1}{2}$  of the peak value.

Figure 10: Typical Polar Radiation Pattern

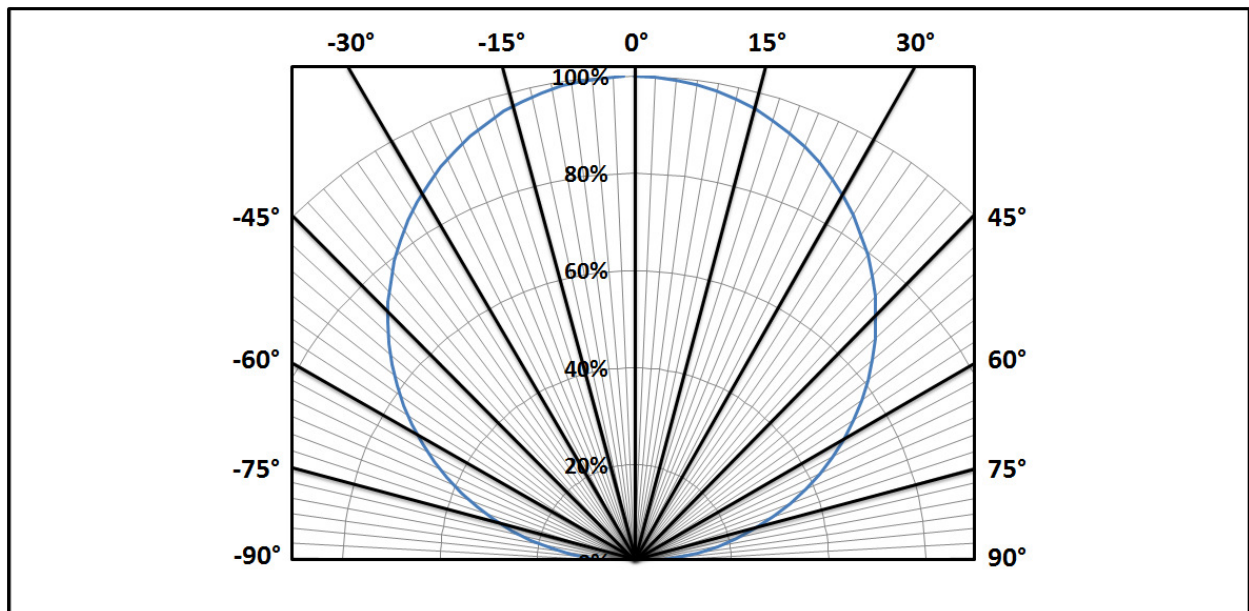

## Typical Color Spectrum

Figure 11: Typical Color Spectrum

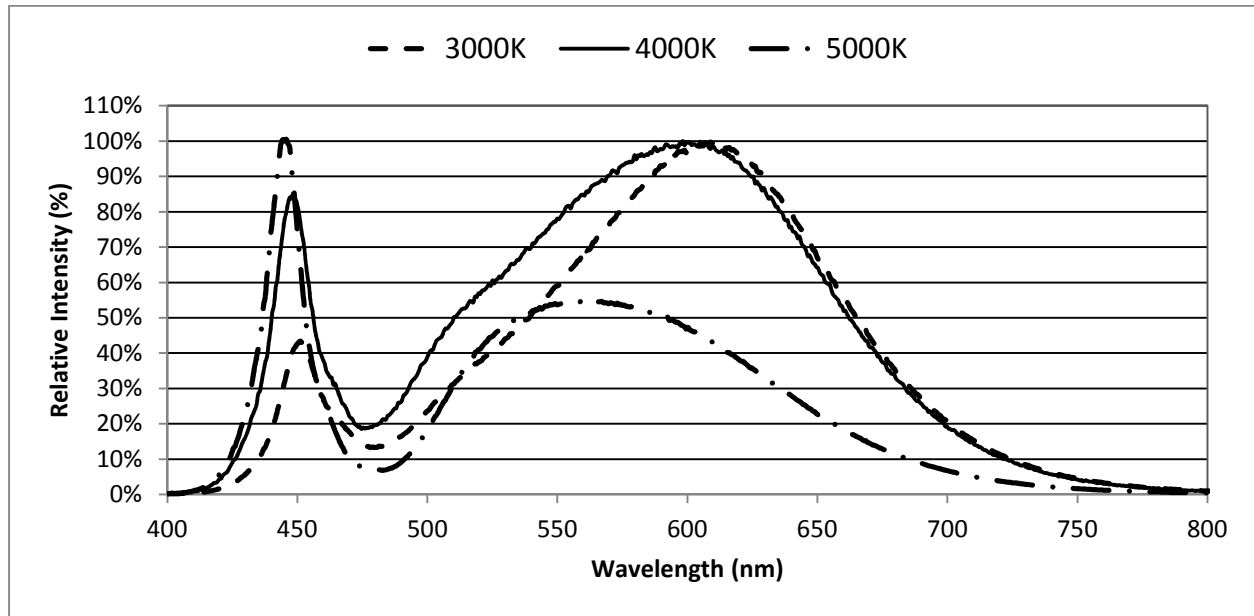

Notes for Figure 11:

1. Color spectra measured at rated current for  $T_j = T_c = 25^\circ\text{C}$ .
2. Color spectrum shown for warm white is 3000K and 80 CRI.
3. Color spectrum shown for neutral white is 4000K and 80 CRI.
4. Color spectrum shown for cool white is 5000K and 70 CRI.

## Mechanical Dimensions

Figure 12: Drawing for V6 Arrays

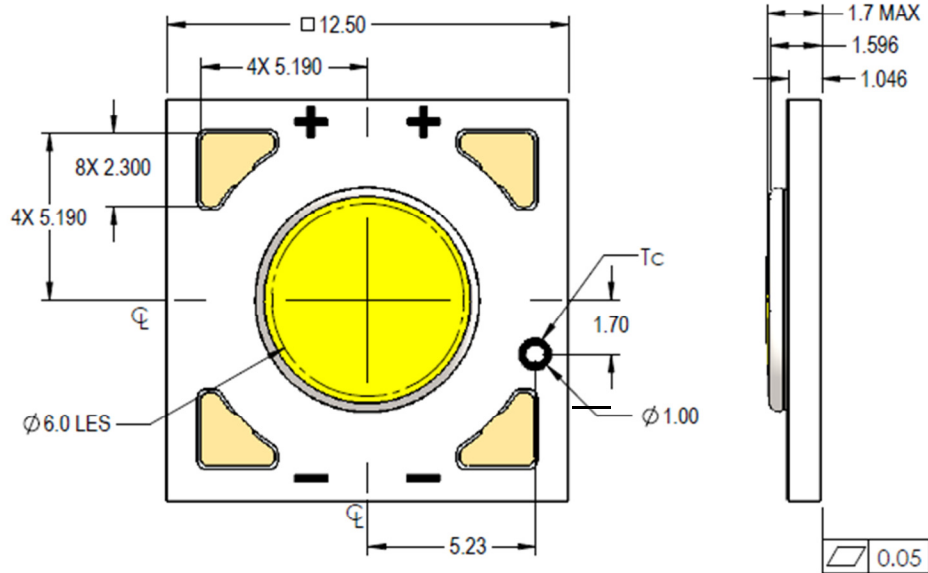

### Notes for Figure 12:

1. Solder pads are labeled "+" and "-" to denote positive and negative polarity, respectively.
2. It is not necessary to provide electrical connections to both sets of solder pads. Either set may be used depending on application specific design requirements.
3. Drawings are not to scale.
4. Drawing dimensions are in millimeters.
5. Unless otherwise specified, tolerances are  $\pm 0.10\text{mm}$ .
6. The optical center of the LED Array is nominally defined by the mechanical center of the array. The light emitting surface (LES) is centered on the mechanical center of the array to a tolerance of  $\pm 0.45\text{ mm}$
7. Bridgelux maintains a flatness of 0.1 mm across the mounting surface of the array. Refer to Application Notes AN40 and AN41 for product handling, mounting and heat sink recommendations.



## Color Binning Information

Figure 13: Graph of Warm White Test Bins in xy Color Space

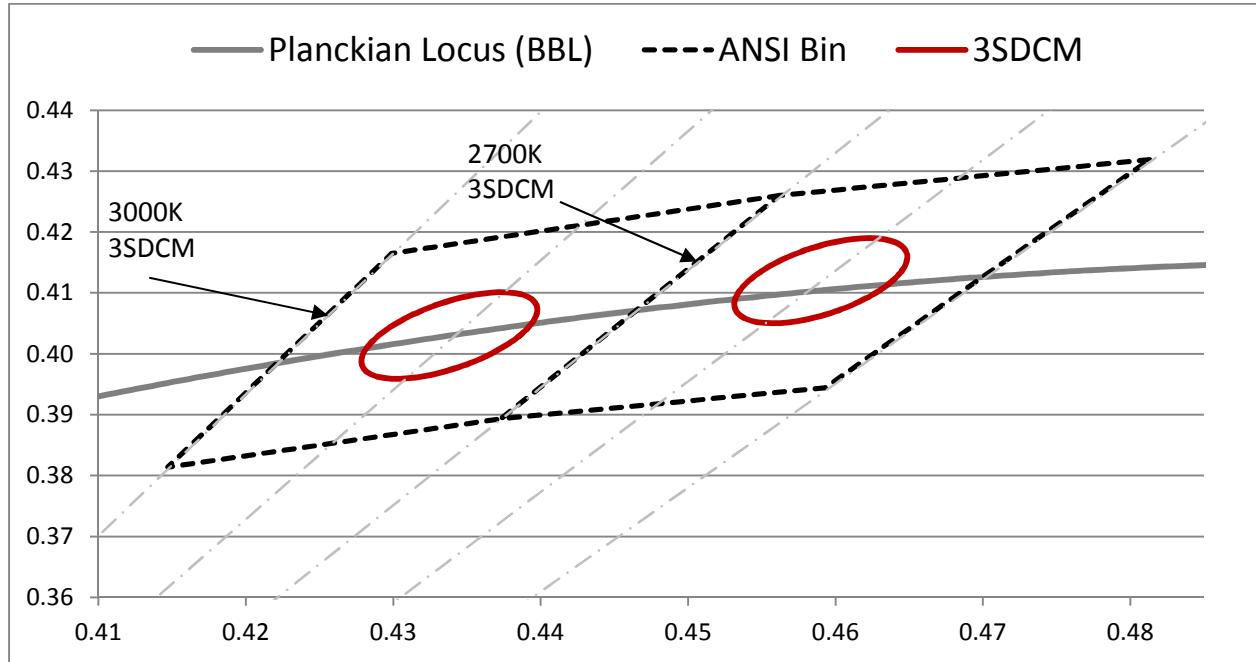

Notes for Figure 13:

1. 3SDCM bins are shown inside standard ANSI bins for comparison purposes.

Table 6: Warm White xy Bin Coordinates and Associated Typical CCT

Bin Code	2700K	3000K
ANSI Bin (for reference only)	(2580K - 2870K)	(2870K - 3220K)
03 (3SDCM)	(2651K - 2794K)	(2968K - 3136K)
Center Point (x,y)	(0.4578, 0.4101)	(0.4338, 0.403)

## Color Binning Information (continued)

Figure 14: Graph of Neutral White Test Bins in xy Color Space

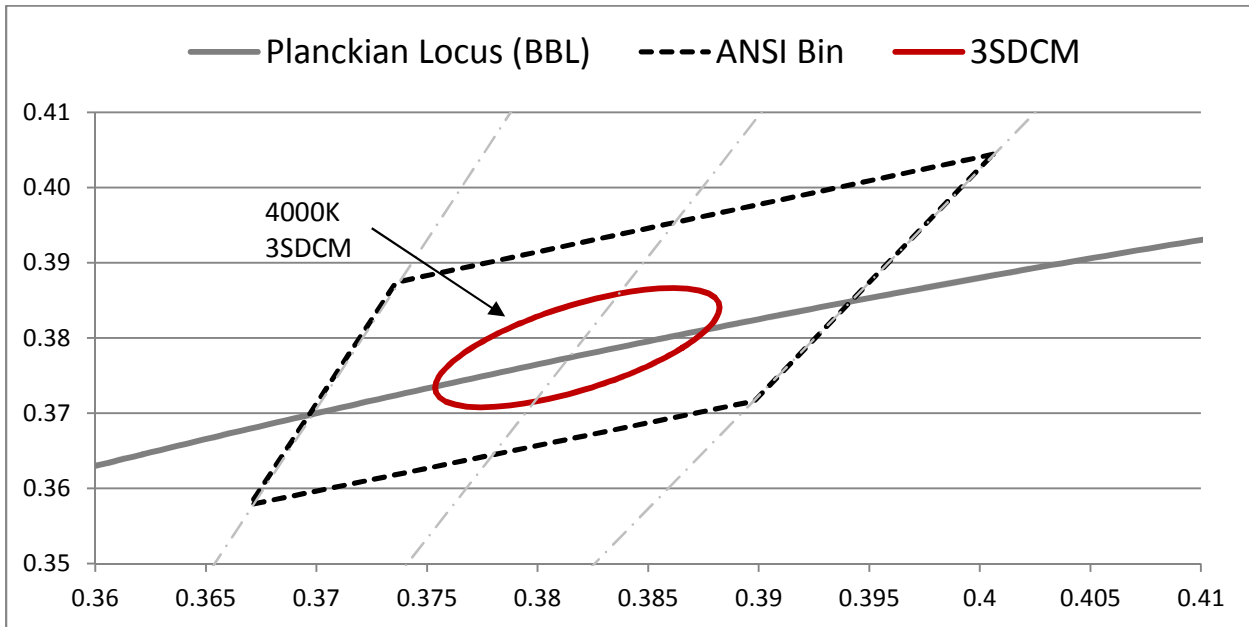

Notes for Figure 14:

1. 3SDCM bin is shown inside standard ANSI bins for comparison purposes.

Table 7: Neutral White xy Bin Coordinates and Associated Typical CCT

Bin Code	4000K
ANSI Bin (for reference only)	(3710K - 4260K)
03 (3SDCM)	(3851K - 4130K)
Center Point (x,y)	(0.3818, 0.3797)

## Color Binning Information (continued)

Figure 15: Graph of Cool White Test Bins in xy Color Space

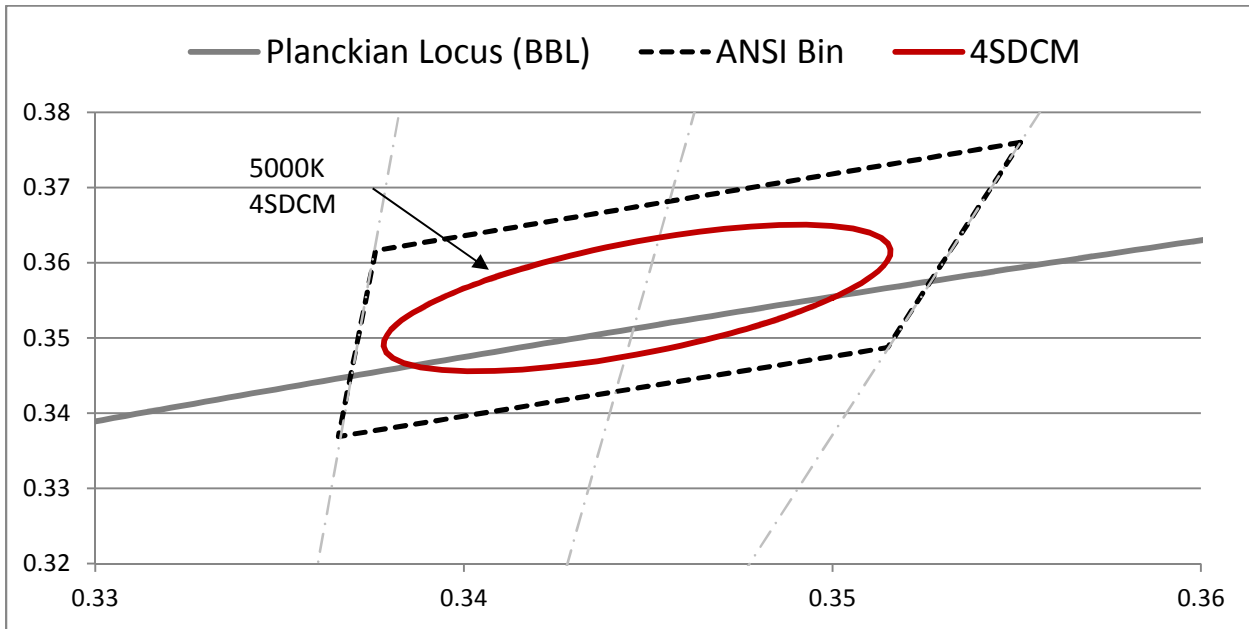

Notes for Figure 15:

1. 4SDCM bin is shown inside standard ANSI bins for comparison purposes.

Table 8: Cool White xy Bin Coordinates and Associated Typical CCT

Bin Code	5000K
ANSI Bin (for reference only)	(4745K - 5311K)
04 (4SDCM)	(4801K - 5282K)
Center Point (x,y)	(0.3447, 0.3553)

# Packaging and Labeling

Figure 16: Drawing for V6 packaging tray

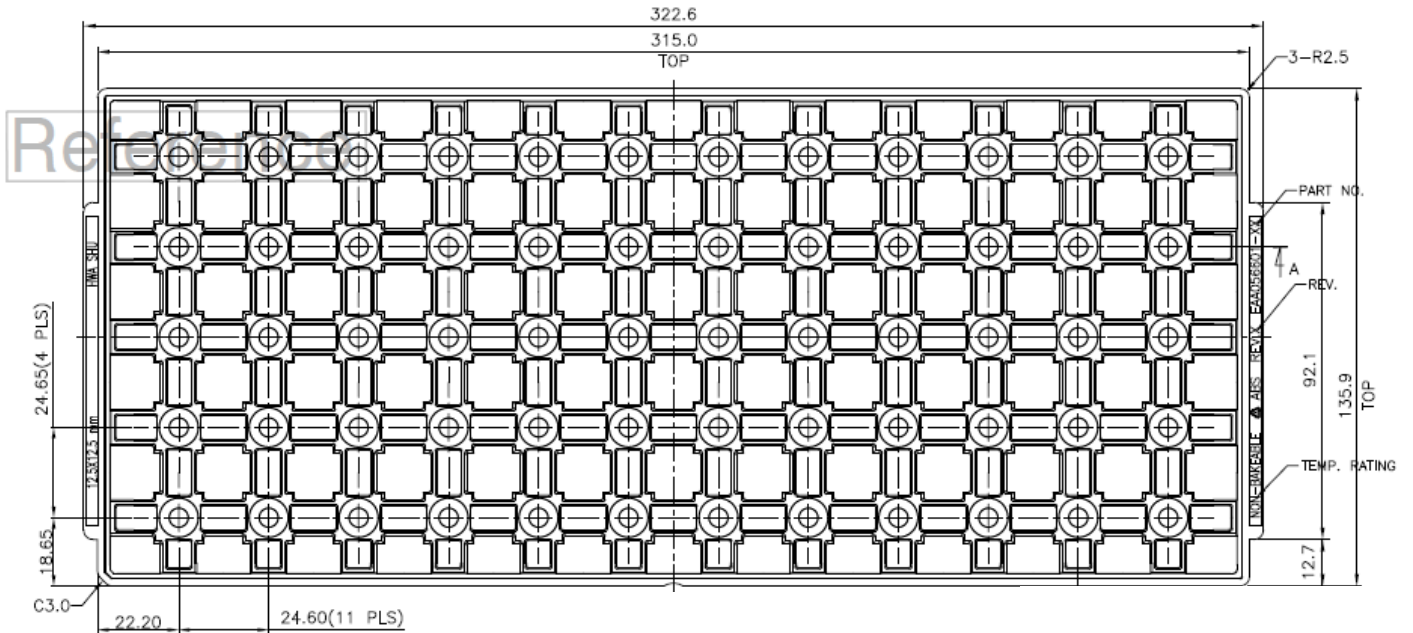

Notes for Figure 16:

1. Dimensions are in millimeters
2. Tolerances: X.X =  $\pm 0.25$ , X.XX =  $\pm 0.13$ , X°0' =  $\pm 0^{\circ}30'$
3. Trays are stackable without interference and will not stick together during unstacking operation

## Packaging and Labeling (continued)

Figure 17: V Series packaging and labeling

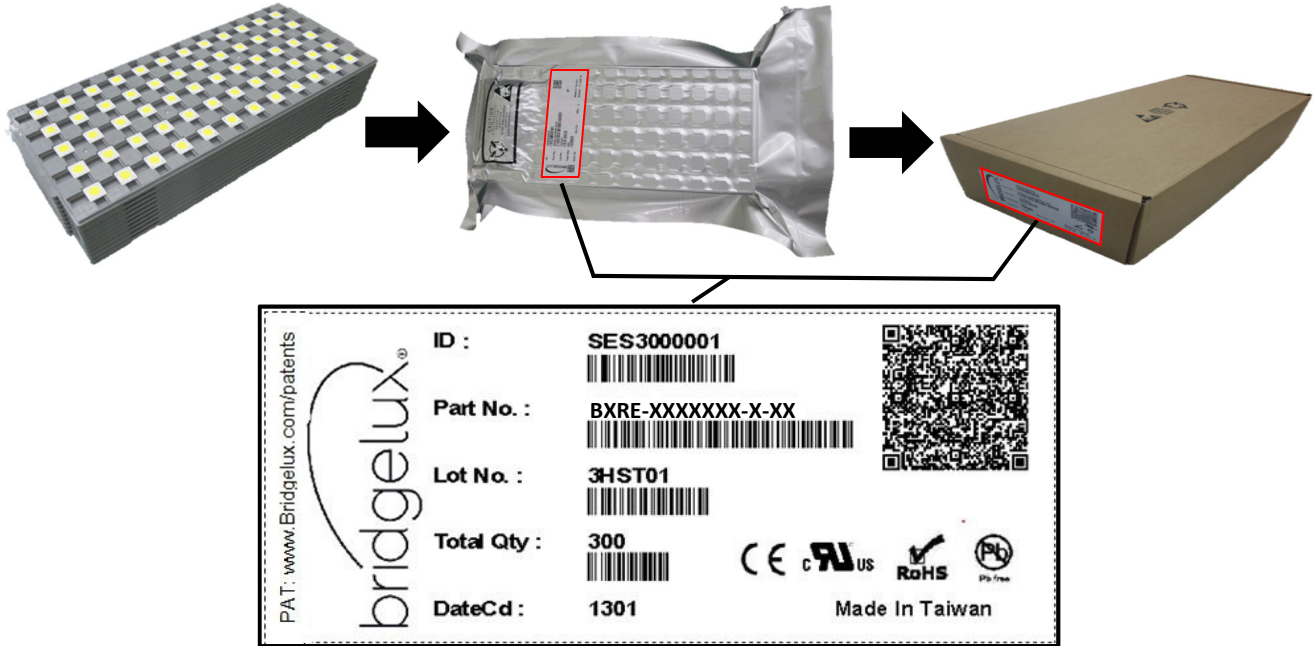

Notes for Figure 17:

1. Each tray holds 60 LEDs, 10 trays are stacked and one empty tray placed on top to cover the top tray.
2. Stacked trays are to contain only 1 part number and be vacuum sealed in an anti-static bag and placed in its own individual box.
3. Each bag and box is to be labeled as shown above.

## Design Resources

Bridgelux has developed a comprehensive set of application notes and design resources to assist customers in successfully designing with Bridgelux LED Array products. Included below is a list of available resources which can be downloaded from the Bridgelux web site under the Design Resources section.

These documents are updated regularly as new information becomes available, including complimentary infrastructure products such as commercially available secondary optics and electronic driver solutions.

### Application Notes

- AN40: Effective Thermal Management of Bridgelux V Series LED Arrays
- AN41: Assembly Considerations for Bridgelux V Series LED Arrays
- AN42: Electrical Drive Considerations for Bridgelux V Series LED Arrays
- AN34: Reliability Data Sheet for Bridgelux LED Arrays
- AN46: Optical Considerations for Bridgelux V Series LED Arrays

### Optical Source Models

Optical source models and ray set files are available for all Bridgelux LED Array products, and can be downloaded directly from the Bridgelux web site. The list below contains the formats currently available. If you require a specific format not included in this list, please contact your Bridgelux sales representative for assistance.

- Zemax
- ASAP
- IESNA
- LightTools
- LucidShape
- OPTIS SPEOS
- PHOTOPIA
- TracePro
- Radiant Imaging Source Model

### 3D CAD Models

Three dimensional CAD models depicting the product outline of all Bridgelux LED Arrays are available in both SAT and STEP formats. These CAD files can be downloaded directly from the Bridgelux web site.

## About Bridgelux

Bridgelux is a leading developer and manufacturer of technologies and solutions transforming the \$40 billion global lighting industry into a \$100 billion market opportunity. Based in Livermore, California, Bridgelux is a pioneer in solid-state lighting (SSL), expanding the market for light-emitting diode (LED) technologies by driving down the cost of LED lighting systems. Bridgelux's patented light source technology replaces traditional technologies (such as incandescent, halogen, fluorescent and high intensity discharge lighting) with integrated, solid-state lighting solutions that enable lamp and luminaire manufacturers to provide high performance and energy-efficient white light for the rapidly growing interior and exterior lighting markets, including street lights, commercial lighting and consumer applications. With more than 550 patent applications filed or granted worldwide, Bridgelux is the only vertically integrated LED manufacturer and developer of solid-state light sources that designs its solutions specifically for the lighting industry.

For more information about the company, please visit [www.bridgelux.com](http://www.bridgelux.com)



© 2014 Bridgelux, Inc. All rights reserved. Product specifications are subject to change without notice.