

Classic Globe 150 LED 3000K

The Classic series is an old favourite of our assortment. Ideal in most areas where functionality and timeless design are the key words. Classic is available in different combinations and are also available with a grey or a brown glazed base as option.

EAN / GTIN	7312906044822
E-number	7502734
Article no.	6044-800-10
Type designation	52726/LED



Specification

Material	Porcelain
Base colour	White (NCS S 1502-G50Y)
Glass	Matt opal glass
Glass thread (mm)	84,5 mm
Glass gasket	Silicone
Weight	0,98 kg
Diameter (mm)	150
Height (mm)	193
Lamp holder	LED
Light source	LED module, 8W **
Effect	8W
Lumen, light source	800lm
Lumen, luminair	687
Colour temperature	3000K
MacAdam	3
Life span	L80/B10: 47 000 h
Ra	Min 90
Rated voltage	230V
Dimmable	RC mode
IP class	IP54
Insulation class	I
Energy class	F
D class	No
IK class	IK02
Ta	-30 - +25
Installation	Wall
CC measurement (mm)	60-66
Knock out opening	1 - demands glands
Cable inlet	Bottom inlet
Cable glands	Bottom inlet
Cable area, max	Max 3 x 2,5 mm ²
Bridging	Yes
Surface mounted cable	Yes
Connection	Terminal block
Family	Classic Globe
Design	Ifö Electric

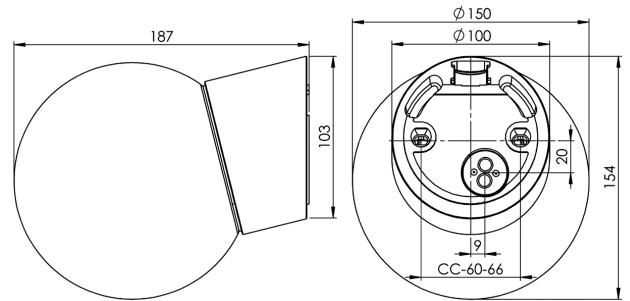
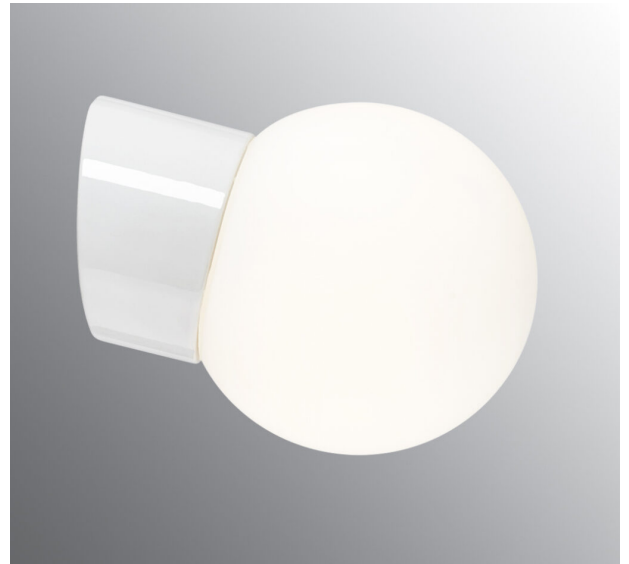

Luminaire specific information

Angeled 14 degrees.

Maintenance

Disconnect the power to the luminaire. Unscrew the glass and clean it. Do not use detergents that contain solvents. Replace light source if necessary. Check the gasket and replace it if necessary. Screw the shade back on.

Spare parts

Shade globe, Ø 150 mm matt opal, Article no.: 1-6108-1
 Gasket silikon for thread 84,5 mm, Article no.: 02786-9
 LED module 8W - 3000K, Article no.: 1-54057-930

** The device must under no circumstances be connected to the same phase as a magnetic ballast or other older fluorescent luminaires as these luminaires can generate overvoltage transients outside of EU regulatory standards when switched off or on. The luminaire can permanently damage or completely cease to function when connected.

If the luminaire is modified the person responsible for the modification shall be considered manufacturer. Subject to errors in text. We reserve the right to change the technical specifications (without notice).